

SARATOGA

10-1/2" Top Rail Oval Pools

Parts List

Oval Pools — Parts List

ITEM #	DESCRIPTION	24' x 12'		24' x 16'		28' x 16'		32' x 16'		34' x 18'		41' x 21'	
		PART#	QTY.	PART#	QTY.	PART#	QTY.	PART#	QTY.	PART #	QTY.	PART #	QTY.
	ASSEMBLY PACK - 52"	0-9942-006	1	0-9946-006	1	0-9986-006	1	0-9926-006	1	0-9948-006	1	0-9911-006	1
*1.	Plastic Coping 24"	545-1001	33	545-1001	36	545-1001	40	545-1001	44	545-1001	46	545-1001	55
2.	Vertical End Cap 10-1/2"	580-1775	26	580-1775	28	580-1775	30	580-1775	32	580-1775	36	580-1775	42
3.	Vertical Center Section, Side - 52"	341-1491	6	341-1491	4	341-1491	6	341-1491	8	341-1491	8	341-1491	10
4.	Vertical Center Section, End - 52"	341-1490	10	341-1490	12	341-1490	12	341-1490	12	341-1490	14	341-1490	16
5.	Stabilizer Rail-Small	583-1012	8	583-1012	10	583-1012	10	583-1012	10	583-1012	10	**583-1004	12
6.	Stabilizer Rail-Large	_____	—	_____	—	_____	—	_____	—	_____	—	**583-1005	10
6A.	Stabilizer Rail - Large	583-1011	12	583-1011	10	583-1011	12	583-1011	14	583-1011	16	583-1011	8
7.	Bottom Rail (Stamped 16,18 or 21)	589-1046	12	589-1047	10	589-1047	10	589-1047	10	589-1048	16	589-1049	14
8.	Side Rail (Stamped S)	589-1052	4	589-1052	2	589-1052	4	589-1052	6	589-1052	6	589-1052	8
9.	Transition Rail (Stamped TR)	_____	—	589-1053	4	589-1053	4	589-1053	4	_____	—	589-1053	4
10.	Side Vertical Bracket	580-1784	6	580-1784	4	580-1784	6	580-1784	8	580-1784	8	580-1784	10
11.	Side Vertical Bottom Cap	580-1776	12	580-1776	8	580-1776	12	580-1776	16	580-1776	16	580-1776	20
***12.	Sheet Metal Screw #10x1/2"	330-1127	210	330-1127	204	330-1127	234	330-1127	264	330-1127	288	330-1127	342
13.	Magnetic Socket 5/16"	317-1016	1	317-1016	1	317-1016	1	317-1016	1	317-1016	1	317-1016	1
14.	Pool Parts List	573-3495	1	573-3495	1	573-3495	1	573-3495	1	573-3495	1	573-3495	1
15.	Pool Installation Instructions	573-3308	1	573-3308	1	573-3308	1	573-3308	1	573-3308	1	573-3308	1
16.	"Safety First" Booklet	573-3169	1	573-3169	1	573-3169	1	573-3169	1	573-3169	1	573-3169	1
17.	_____	_____	—	_____	—	_____	—	_____	—	_____	—	_____	—
18.	_____	_____	—	_____	—	_____	—	_____	—	_____	—	_____	—
19.	_____	_____	—	_____	—	_____	—	_____	—	_____	—	_____	—
20.	_____	_____	—	_____	—	_____	—	_____	—	_____	—	_____	—
21.	Warranty Card	_____	1	_____	1	_____	1	_____	1	_____	1	_____	1
22.	_____	_____	—	_____	—	_____	—	_____	—	_____	—	_____	—
23.	Top Rail (Common)	587-1638	4	_____	—	_____	—	_____	—	_____	—	_____	—
***24.	Hex Head Bolt 3/8-16x3-1/2"	330-1220	12	330-1220	8	330-1220	12	330-1220	16	330-1220	16	330-1220	20
***25.	Hex Nut 3/8-16	321-1069	12	321-1069	8	321-1069	12	321-1069	16	321-1069	16	321-1069	20
	TOP CONNECTOR PACK	0-9999-016	1	0-9999-016	1	0-9999-018	1	0-9999-020	1	0-9999-022	1	0-9999-026	1
26.	Top Connector	340-1865	16	340-1865	16	340-1865	18	340-1865	20	340-1865	22	340-1865	26
	TOP RAIL PACK	0-9821-005	1	0-9808-005	2	0-9808-005	1	0-9810-005	2	0-9806-005	1	0-9808-005	2
	TOP RAIL PACK	_____	—	_____	—	0-9810-005	1	_____	—	0-9808-005	2	0-9810-005	1
27.	Top Rail	587-1637	12	587-1638	16	587-1638	18	587-1638	20	587-1638	22	587-1638	26
	VERTICAL PACK - 52"	0-9708-010	2	0-9708-010	2	0-9708-010	1	0-9710-010	2	0-9706-010	1	0-9708-010	2
	VERTICAL PACK - 52"	_____	—	_____	—	0-9710-010	1	_____	—	0-9708-010	2	0-9710-010	1
28.	Vertical Side Section - 52"	341-1400	32	341-1400	32	341-1400	36	341-1400	40	341-1400	44	341-1400	52
	POOL LINER CARTON												
****29.	Pool Liner _____	0-2412-____	1	0-2416-____	1	0-2816-____	1	0-3216-____	1	0-3418-____	1	0-4121-____	1
30.	Chlorine/Winterizing Instruct.	573-2421	1	573-2421	1	573-2421	1	573-2421	1	573-2421	1	573-2421	1
31.	"Warning" Decal	560-1041	3	560-1041	3	560-1041	3	560-1041	3	560-1041	3	560-1041	3
32.	Warranty Card - Liner	_____	1	_____	1	_____	1	_____	1	_____	1	_____	1
****33.	Repair Patch	564-1000	1	564-1000	1	564-1000	1	564-1000	1	564-1000	1	564-1000	1
*****34.	"Deeper Area" Decal	560-1042	2	560-1042	2	560-1042	2	560-1042	2	560-1042	2	560-1042	2
35.	"Shallow" Decal, 3-1/2 ft.	560-1043	3	560-1043	3	560-1043	3	560-1043	3	560-1043	3	560-1043	3
35.	"Shallow" Decal, 3-3/4 ft.	560-1056	3	560-1056	3	560-1056	3	560-1056	3	560-1056	3	560-1056	3
36.	Shallow Decal Insert Sheet	369-1216	1	369-1216	1	369-1216	1	369-1216	1	369-1216	1	369-1216	1
37.	"Read Me First" Booklet	573-3169	1	573-3169	1	573-3169	1	573-3169	1	573-3169	1	573-3169	1
38.	_____	_____	—	_____	—	_____	—	_____	—	_____	—	_____	—

Oval Pools — Parts List

ITEM #	DESCRIPTION	24' x 12'		24' x 16'		28' x 16'		32' x 16'		34' x 18'		41' x 21'	
		PART#	QTY.	PART#	QTY.	PART#	QTY.	PART#	QTY.	PART#	QTY.	PART #	QTY.
SIDEWALL CARTON													
39.	Sidewall - 52"	0-0010-042	1	0-0010-046	1	0-0010-086	1	0-0010-026	2	0-0010-048	2	0-0010-011	2
40.	Joint Piece - 52"	580-1914	1	580-1914	1	580-1914	1	580-1914	2	580-1914	2	580-1914	2
41.	Large Cover Plate (not shown)	-----	—	-----	—	-----	—	580-2338	2	580-2338	2	580-2338	2
42.	Small Cover Plate (not shown)	-----	—	-----	—	-----	—	580-2339	2	580-2339	2	580-2339	2
43.	"Warning" Sign	560-1046	1	560-1046	1	560-1046	1	560-1046	2	560-1046	2	560-1046	2
44.	"Read Me First" Booklet	573-3169	1	573-3169	1	573-3169	1	573-3169	2	573-3169	2	573-3169	2
45.	Adhesive Squares	310-1034	6	310-1034	6	310-1034	6	310-1034	12	310-1034	12	310-1034	12
46.	Safety Video	573-2500	1	573-2500	1	573-2500	1	573-2500	2	573-2500	2	573-2500	2
	SUPPORT BASE PACK 4 - CARTON	-----	—	0-8888-204	1	-----	—	0-8888-204	2	0-8888-204	2	0-8888-204	1
	SUPPORT BASE PACK 6 - CARTON	0-8888-206	1	-----	—	0-8888-206	1	-----	—	-----	—	0-8888-206	1
47.	Skid Support	580-1779	6	580-1779	4	580-1779	6	580-1779	8	580-1779	8	580-1779	10
48.	Ground Support - Top	580-2071	6	580-2071	4	580-2071	6	580-2071	8	580-2071	8	580-2071	10
49.	Ground Support - Bottom	580-2072	6	580-2072	4	580-2072	6	580-2072	8	580-2072	8	580-2072	10
50.	Pressure Pad - Outside	580-1869	6	580-1869	4	580-1869	6	580-1869	8	580-1869	8	580-1869	10
51.	Pressure Pad - Side Vertical	580-1870	6	580-1870	4	580-1870	6	580-1870	8	580-1870	8	580-1870	10
52.	Bottom Rail Locator	580-1792	6	580-1792	4	580-1792	6	580-1792	8	580-1792	8	580-1792	10
***53.	Sheet Metal Screw #12x3/4"	510-1035	36	510-1035	24	510-1035	36	510-1035	48	510-1035	48	510-1035	60
***54.	Hex Head Bolt 3/8-16x3-1/2"	330-1220	24	330-1220	16	330-1220	24	330-1220	32	330-1220	32	330-1220	40
***55.	Hex Nut 3/8-16	321-1069	24	321-1069	16	321-1069	24	321-1069	32	321-1069	32	321-1069	40
***56.	Hex Head Screw 1/4-20x1/2"	510-1018	24	510-1018	16	510-1018	24	510-1018	32	510-1018	32	510-1018	40
***57.	Hex Nut 1/4x20	511-1000	24	511-1000	16	511-1000	24	511-1000	32	511-1000	32	511-1000	40
***58.	Sheet Metal Screw #10x1/2"	330-1127	36	330-1127	24	330-1127	36	330-1127	48	330-1127	48	330-1127	60
	SUPPORT PACK 4 - CARTON - 52"	-----	—	0-8852-400	1	-----	—	0-8852-400	2	0-8852-400	2	0-8852-400	1
	SUPPORT PACK 6 - CARTON - 52"	0-8852-600	1	-----	—	0-8852-600	1	-----	—	-----	—	0-8852-600	1
59.	Side Vertical - 52"	580-2074	6	580-2074	4	580-2074	6	580-2074	8	580-2074	8	580-2074	10

*For use with stretch-in liners only.

** These stabilizer rails are used on the round ends of the pool only. Part No. 583-1011 is used between side verticals.

***Screws, nuts and washers are available at your local hardware store.

***For future reference, write your Liner Part No. here _____

**** For additional patch kits, order part number 0-5604-000.

***** Used for pools with deep swimming areas only.

EXPLODED VIEW

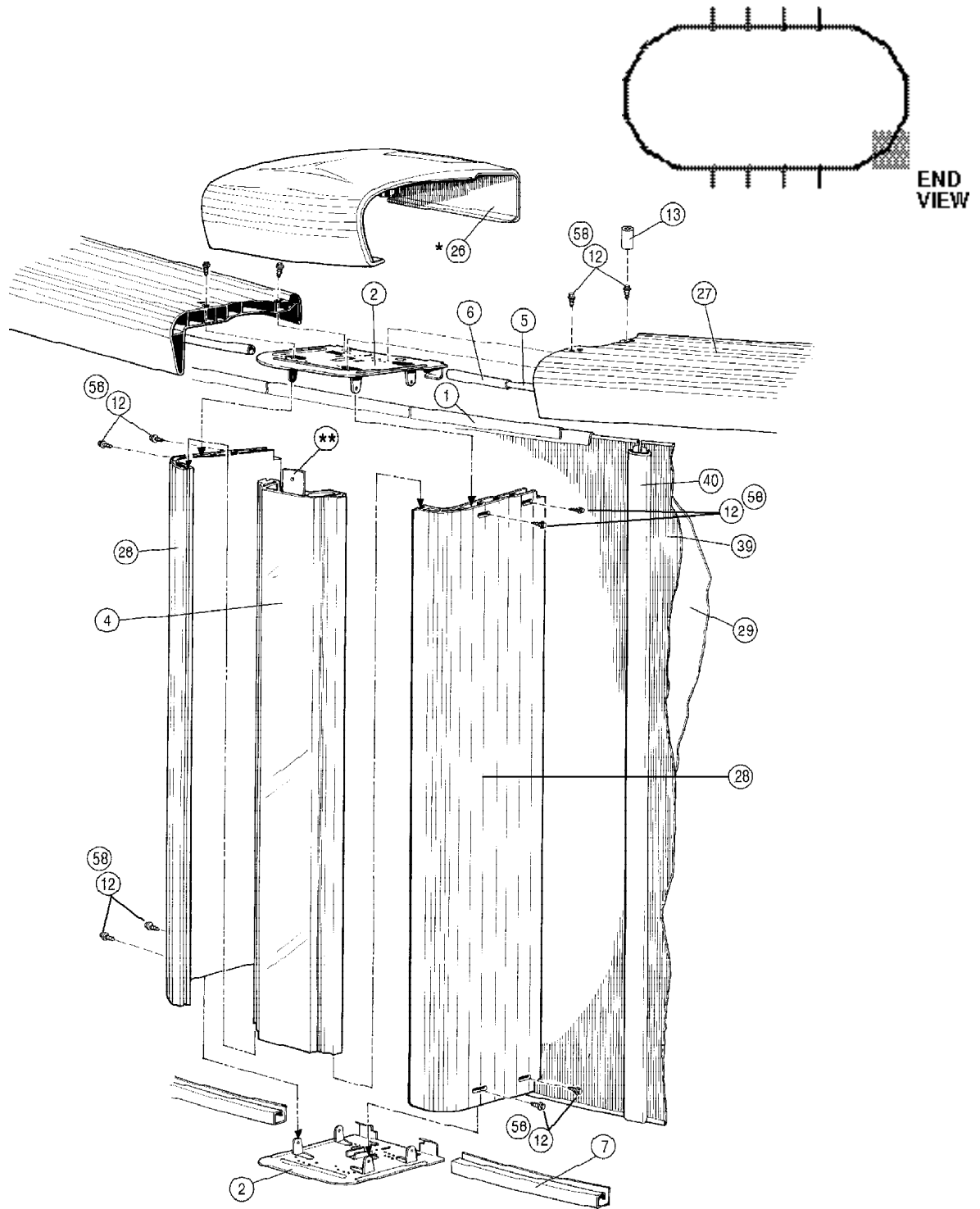

* **CAUTION:** To prevent a potentially damaging heat rise condition from occurring under your pool's winter cover, do not leave your cover on your pool too long at the beginning of the swimming season, or install it too soon at the end of the season. Warping of pool parts due to excessive heat is not considered to be a manufacturer's defect under the terms of your warranty.

** Fencing strips required and supplied with optional fencing only.

EXPLODED VIEW

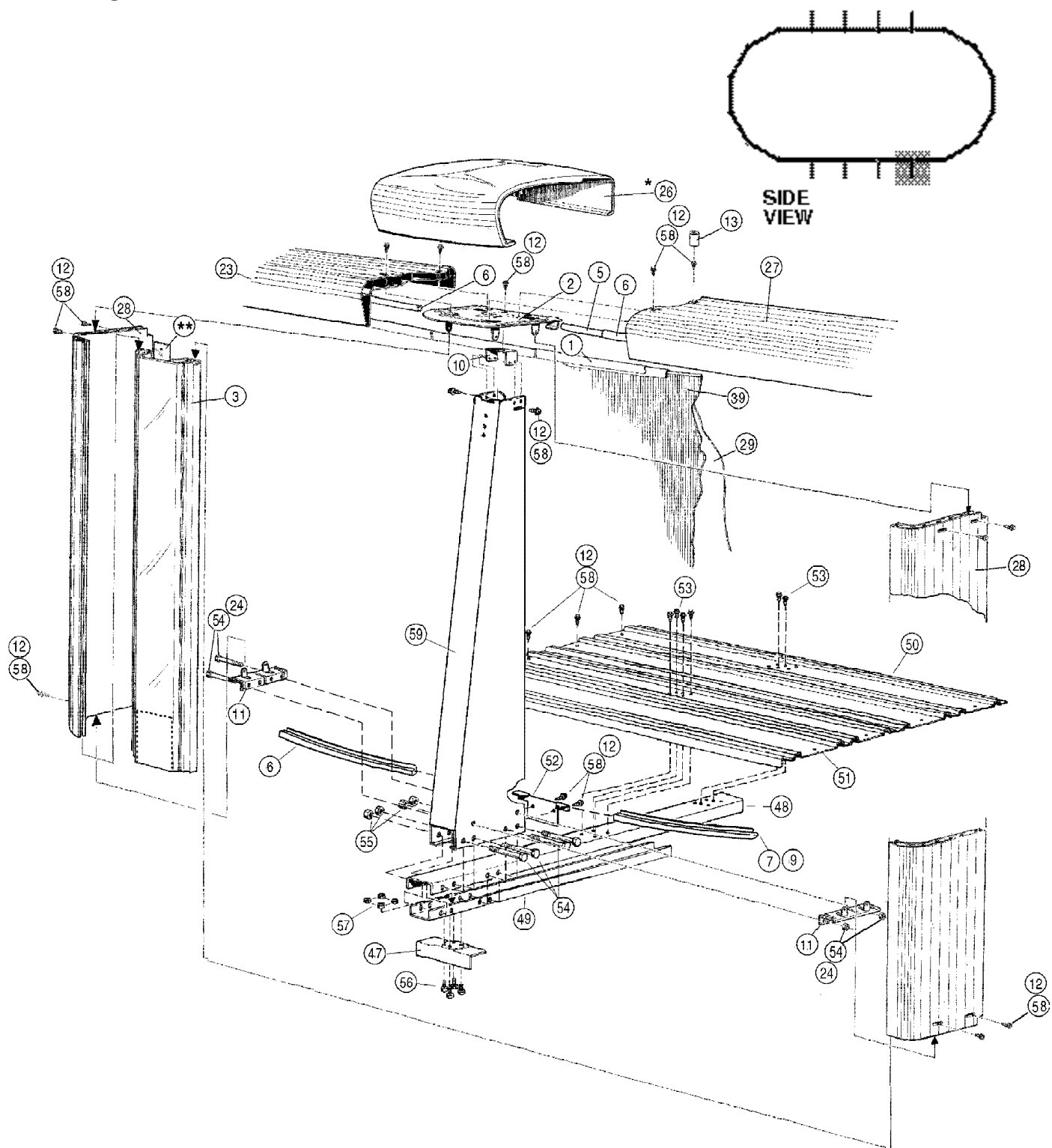

*** CAUTION:** To prevent a potentially damaging heat rise condition from occurring under your pool's winter cover, do not leave your cover on your pool too long at the beginning of the swimming season, or install it too soon at the end of the season. Warping of pool parts due to excessive heat is not considered to be a manufacturer's defect under the terms of your warranty.

** Fencing strips required and supplied with optional fencing only.



Important! Above-ground pools are designed for swimming and wading only. **Do not Dive or Jump!** Misuse of your pool may result in crippling injury and/or other dangers to life and health. Do not use slides, diving boards, or any other platform or object which can be used for improper pool entry. Use only an above-ground swimming pool ladder or entry system to enter or exit your pool. **Never attempt to swim or reach behind ladders or any other pool entry system.** It is the pool owner's responsibility to secure the pool against unauthorized, unsupervised or unintentional entry. It is also the pool owner's responsibility to warn all pool users of the hazards of diving into shallow water: paralyzing injury may result. Always obey all safety rules. Remember, pool safety is everybody's responsibility.

Safety decals and caution information provided with your pool have been endorsed by the U.S. Consumer Product Safety Commission. It is mandatory that the pool owner and installer follow the installation and use directions for all provided safety signs and decals. Juveniles must be supervised at all times by a responsible adult as directed by the USCPSC.

Change of Design: Doughboy Recreational expressly reserves the right to change or modify the design and construction of any product in due course of their manufacturing procedures, without incurring any obligation to furnish or install such changes or modifications on products previously or subsequently sold.

DOUGHBOY RECREATIONAL • 315 N. Sebastian St. • West Helena, AR 72390
Visit our website at www.doughboy-pools.com